



INSTALLATION GUIDE FOR STUD AND BRICK

Gold Wall System

Wall soundproofing for airborne noise issues.

Installation overview - stud wall

1. 5 x 60mm Wood Screws
2. 20mm Self Tapping Screws
3. 32mm Fine Thread Dry Wall Screws
4. 50mm Fine Thread Dry Wall Screws
5. Sealant Spatula and Gun
6. Drill
7. Saw

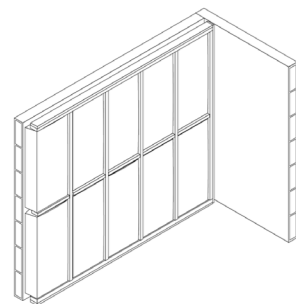
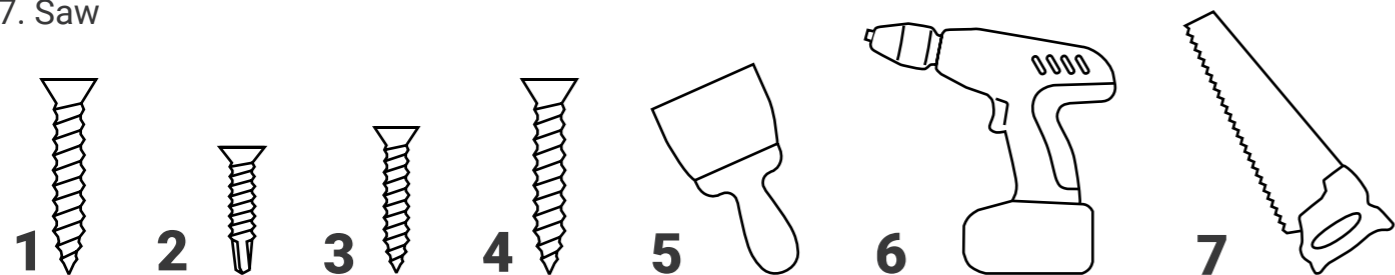

1
Remove your current wall surface, the coving and skirting board. Install acoustic mineral wool into the cavities.

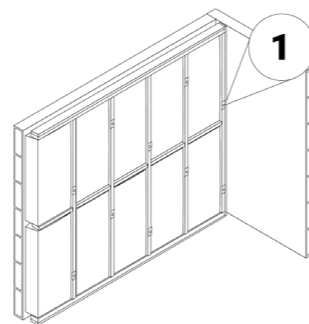

2
Screw the MuteClips to your wall in a diamond formation.

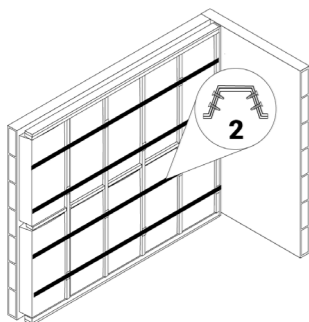

3
Clip channels into the claws and ensure a 2-5mm gap is left around the edges. Clip lengths shorter with tin snips or screw together with self tapping screws.

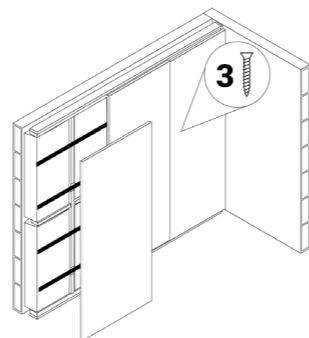

4
Score and snap plasterboard to size and screw into the metal channels.

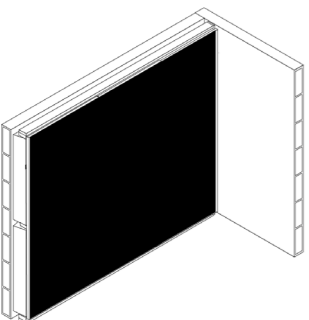

5
Adhere Tecsound to the wall and trim with a sharp blade.

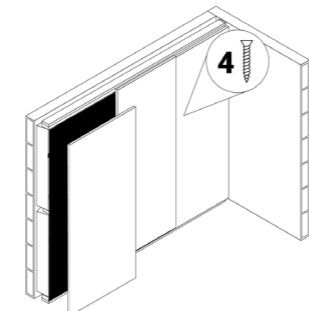

6
Install the final layer and fill gaps with acoustic sealant and cover joints between boards with scrim tape, ready for plastering.

System Components



1
Acoustic plasterboard has a higher mass than regular panels and will reflect airborne noises. These are screwed into the MuteClip frame work.



4
Visco-elastic membranes are thin but have incredible mass. These reflect airborne noises and introduce flex to the rigid boards.



3
Acoustic mineral wool of 60kg/m³ or more is best for ceilings. The high mass gives it acoustic properties thermal insulation doesn't have.

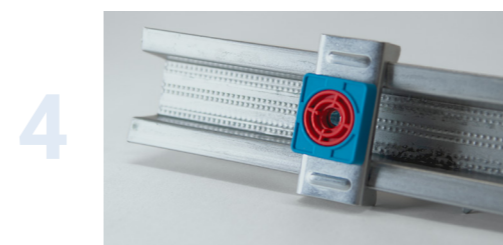

4
MuteClips and metal furring channels suspend your new soundproofing boards away from the existing wall. These decouple the system and provide the best reduction for space used.

Ancillaries required

- **Acoustic sealant**, this is needed to seal gaps and cracks between layers. Making a system airtight improves the soundproofing quality and this sealant also dissipates vibrations.
- **Scrim tape**, this is used over joins between acoustic plasterboards and offers good adhesion with a skim plaster layer.
- **5 x 60mm wood screws**, these are used to join the MuteClips to **stud walls**.
- **Raw plug and screw**, these are used to join MuteClips to **brick walls**.
- **32mm fine thread dry wall screws**, these are used to join the first layer of plasterboard to the furring channels.
- **50mm fine thread dry wall screws**, these screw the second layer onto the wall.
- **20mm self tapping screws**, these join two length of furring channel together.

Tools required

- **Saw or serrated knife**, either tool can be used to cut through acoustic mineral wool with ease.
- **Drill**, use to attach layers of boarding.
- **Tin Snips** to cut lengths of furring channel.
- **Cutting tool**, a Stanley knife, or similar, is used to cut both plasterboard and Tecsound.
- **PPE**, gloves, mask and goggles are suggested when handling acoustic mineral wool.
- **Sealant gun and spatula**, these are needed to correctly apply the acoustic sealant.
- **Plasterboard lift**, optional, but relatively inexpensive to hire. This is a very safe and easy way to lift and position your boards.

FAQ's

Alcoves and chimney breasts

If you have awkward features, such as alcoves and chimney breasts, then you can find out how to soundproof around these with our additional guide which can be found on our website, or click here.

Can I soundproof over my existing wall surface?

If this is for a stud wall, then no. You must remove the stud wall surface so you can remove any thermal insulation and replace it with acoustic insulation. If you have plaster over a brick wall, then this can stay. Dot and dab plasterboard over a brick wall must be removed.

Can I use ordinary fiber glass insulation instead of acoustic mineral wool?

No, this won't work as standard wall and ceiling insulation has thermal properties, not acoustic. To be acoustic it needs a density of 45kg/m³ or more. For ceilings we always recommend 60kg/m³ or more.

Can I reinstate my coving?

Best practice is not to reinstate ceiling coving when you are soundproofing a wall or your ceiling. However, we understand that many people enjoy this feature and so we have a simple method for reinstating it after your soundproofing has been completed. It's a simple process and is outlined in this installation guide for you.

Can I just use ordinary plasterboard?

While they look the same, acoustic plasterboard has a much higher mass. This means it can reflect more airborne noise, like talking or music. This makes your soundproofing much more effective and is why we use this specialist material.

What about my sockets?

It's best to rewire sockets to another wall, however we understand this might not be possible. We include instructions for sockets and switches in this installation guide.

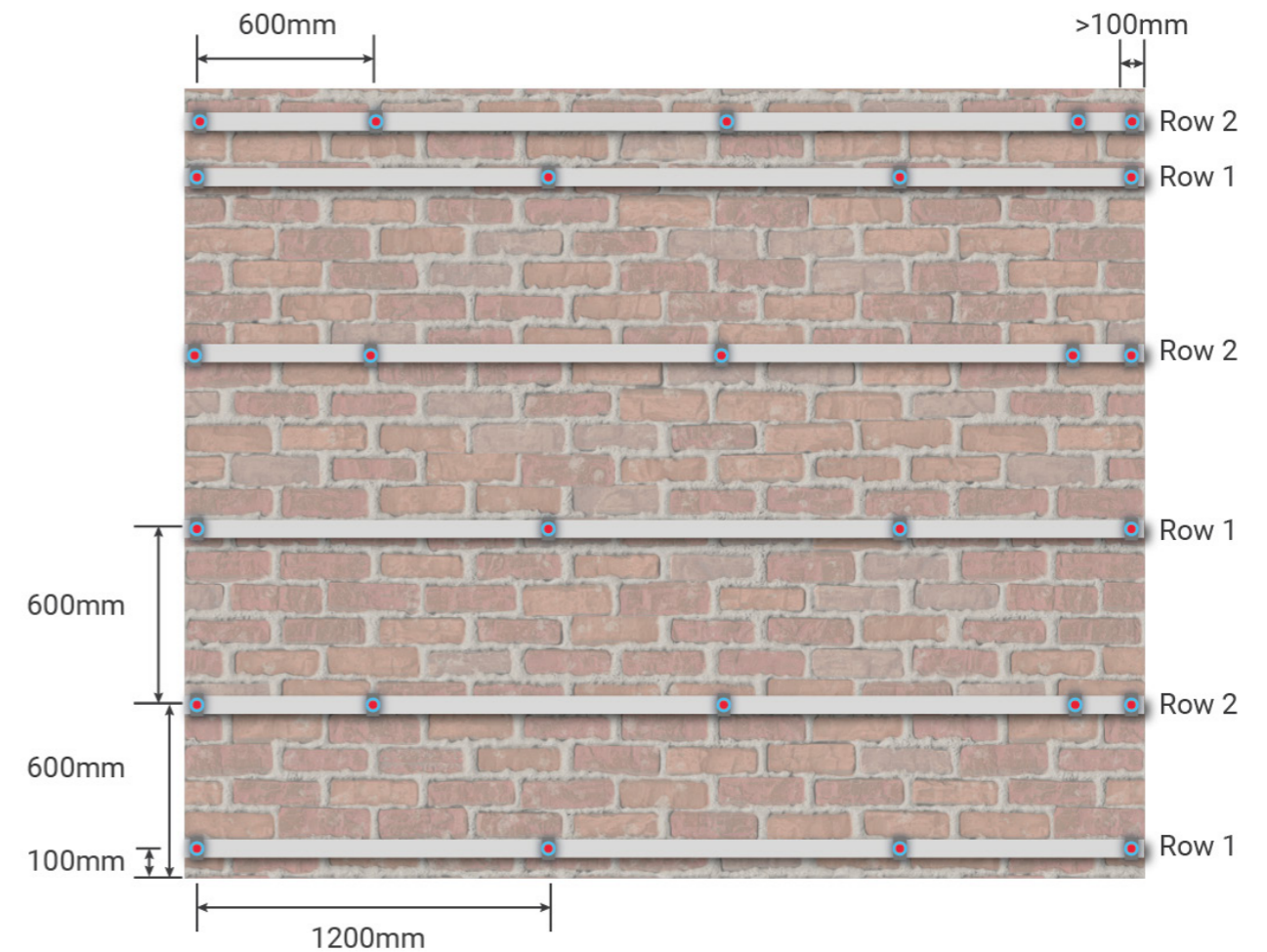

MuteClip Configuration - Brick Wall

To create your new soundproofing frame we need to install the clips in a specific pattern we call the 'diamond formation' this formation can be scaled up or down to suit practically any wall.

- Begin by marking out the spacing for each channel row.
- Starting from the floor, measure up **<100mm for the first row**.
- For the second row, start from the **floor** again and measure up **600mm**.
- For the third row, start from the **floor** and measure up **1200mm**.
- Rows are spaced **600mm** apart but it is most accurate to measure from the floor up.
- The final row should be **<100mm** from the ceiling but no more than **600mm** from the previous row. (sometimes this places two rows closer together, this is not a problem.)
- Now mark the first and last MuteClip position for each row **<100mm** from the perimeter of the wall.
- To create a diamond layout for the clips, the second clip changes position every other row.
- For the bottom row, (Row A layout), mark the second clip at **600mm** from the first clip.
- To complete this row, mark the remaining clips **1200mm** apart. (This will likely place the last two clips closer together than 1200mm which is fine. Never place clips further than 1200mm apart).
- For the second row, (Row B layout), the second clip is spaced **1200mm** from the first clip, **not 600mm** away. This will create the diamond layout you can see.
- Space the rest of the clips **1200mm** apart as normal.
- For the third row return to Row A layout. The layouts should alternate Row A, Row B until the wall is complete.
- To fix the MuteClips to the wall, use a raw plug fixing.

SILVER WALL Installation Video

Follow the step by step installation video below to see how this system is installed. Scan the QR code, or, click the image below to get started.



MuteClip configuration video guide



Wall soundproofing installation guide

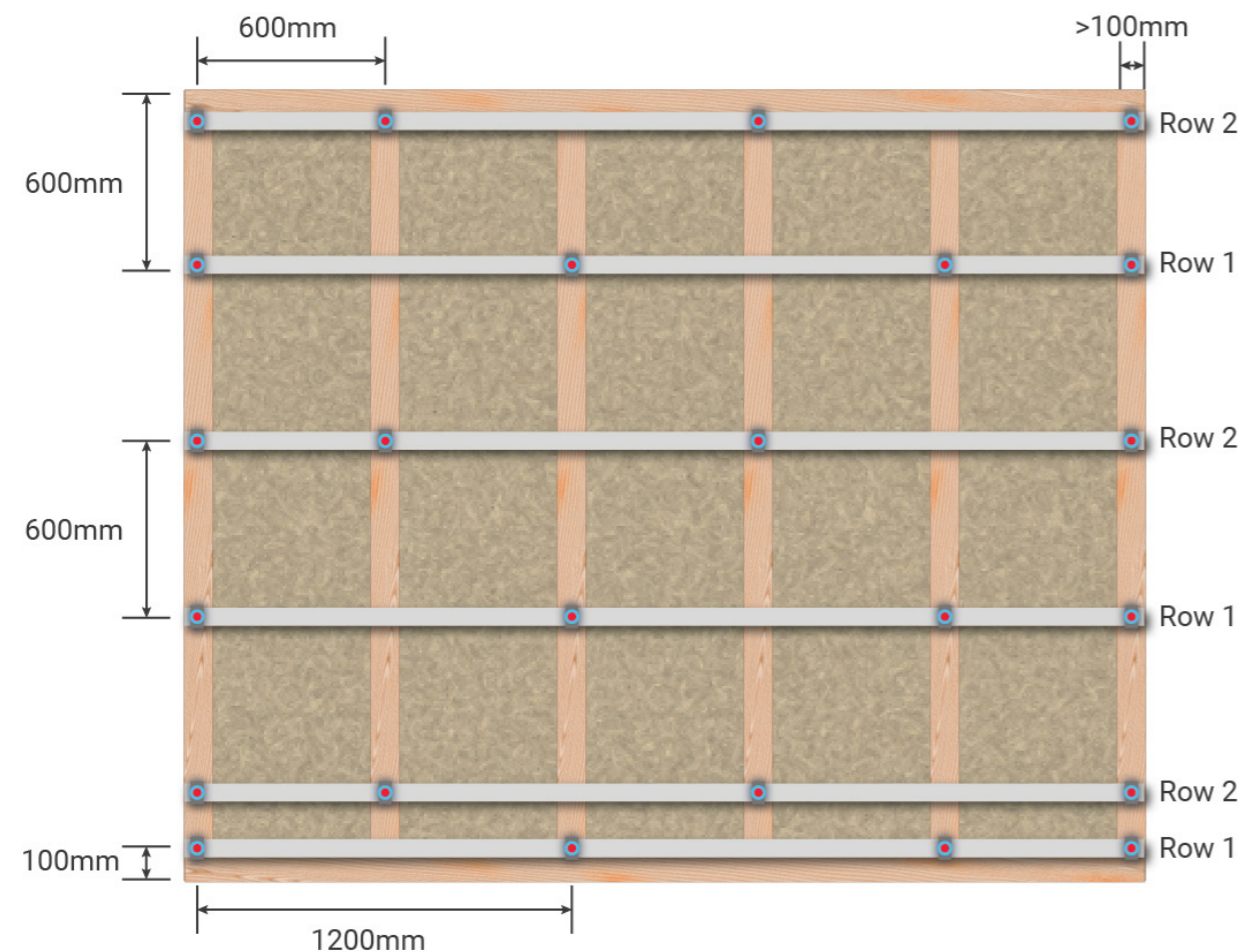

MuteClip Configuration - Stud Wall

To create your new soundproofing frame we need to install the clips in a specific pattern we call the 'diamond formation' this formation can be scaled up or down to suit practically any wall.

- Begin by marking out the spacing for each channel row.
- Starting from the floor, measure up **<100mm for the first row.**
- For the second row, start from the **floor** again and measure up **600mm.**
- For the third row, start from the **floor** and measure up **1200mm.**
- Rows are spaced **600mm** apart but it is most accurate to measure from the floor up.
- The final row should be **<100mm** from the ceiling but no more than **600mm** from the previous row. (sometimes this places two rows closer together, this is not a problem.)
- Now mark the first and last MuteClip position for each row **<100mm** from the perimeter of the wall.
- To create a diamond layout for the clips, the second clip changes position every other row.
- For the bottom row, (Row A layout), mark the second clip at **600mm** from the first clip (onto the first vertical stud).
- To complete this row, mark the remaining clips **1200mm** apart. (This will likely place the last two clips closer together than 1200mm which is fine. Never place clips further than 1200mm apart).
- For the second row, (Row B layout), the second clip is spaced **1200mm** from the first clip, (onto the second vertical stud), **not** 600mm away. This will create the diamond layout you can see.
- Space the rest of the clips **1200mm** apart as normal.
- For the third row return to Row A layout. The layouts should alternate Row A, Row B until the wall is complete.
- To fix the MuteClips to the wall, use 5mm x 60mm wood screws.

GOLD WALL Written Installation Guide

Before starting, get the floor ready. Hard wood flooring can be left in place and the system installed over the top of it. For soft floor finishings, roll them back by more than the system depth. Don't install your soundproofing over soft floor finishings as it creates a weak area and also makes updating the flooring difficult in the future.

Step 1

- Remove your current wall surface and thermal insulation if you have a stud wall.
- If you have a brick wall, remove dot and dab plasterboard. Plaster straight over brick is fine left but fill cracks and gaps.
- For stud and brick, remove coving and skirting boards.
- Roll back soft floor finishes and remove gripper rods.

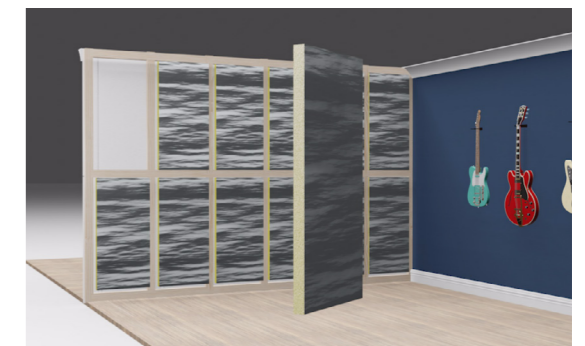

Step 2

- To install a wall mounted socket box, more cable needs to be exposed.
- For plaster or brick, chip into the plaster to expose around **10cm** of wire.
- This can be pulled through as you work on the wall.

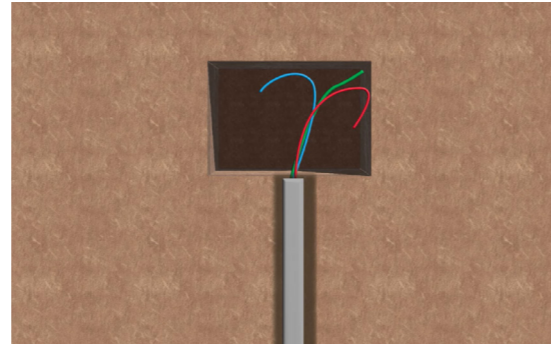

Step 3 - for a brick wall, complete 4&5 first

- Cut slabs of acoustic mineral wool slightly wider than the cavity spaces.
- This will offer a snug fit and the insulation will not require wiring into place.
- Mineral wool can be cut with a serrated knife, or, a saw.



Step 4

- Use the MuteClip guides above to measure and mark your clip spacings.
- Be sure to use **5 x 60mm screws** for stud walls and a **raw plug** and screw for brick walls.
- Do not over tighten the MuteClips, as this will impede performance. They should be able to twist, slightly.



Step 5

- Fit the furring channels into the MuteClip claws by compressing them slightly.
- To cut the channels shorter, use tin snips.
- Channels should not make contact with the adjacent walls, leave a **2-5mm gap**.



Step 6

- To join two lengths, create an overlap of **200mm**.
- Through the shoulder, screw two 20mm self tapping screws on each side. A total of four.
- This join **must not** occur through a Muteclip.
- Mark the central location of each channel row on the adjacent walls to help you line up screws later on.

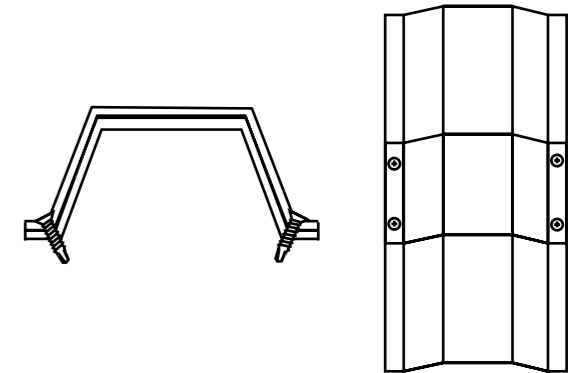

Step 7

- Fit the acoustic plasterboards to the MuteClip furring channels with **32mm fine thread dry wall screws**.
- Use packers around the perimeter of the whole wall to retain a **2-5mm gap**.
- To cut boards smaller, score with a sharp blade and snap.



Step 8

- Fill the perimeter gap and gaps between boards with acoustic sealant.
- Do not swap this for a caulk because it has a rigid set.



Step 9

- Starting from the top, adhere the membrane to the plasterboard.
- Peel back part of the film to tack it to the top and then slowly pull back the rest while smoothing the membrane to the wall as you go.
- Remove any air bubbles that appear.
- To create a seamless joint between pieces, overlap the membrane by a few inches.
- Run a blade down the overlap and remove the excess.



Step 10

- Use the marking you made on the adjacent walls to create chalk lines that denote the channel placement.
- Use **50mm fine thread dry wall screws** to attach the second layer of acoustic plasterboard to the channels.
- Once again leave a **2-5mm gap** around the perimeter of the whole wall.
- Use packers to help you.



Step 11

- Fill gaps and cracks with acoustic sealant.
- Cover the joints between boards with scrim tape.
- Skim plaster of your wall.



Step 13

- To reinstate coving, adhere it to the wall only.
- Create another **2-5mm gap** from the ceiling.
- Fill this gap with acoustic sealant.

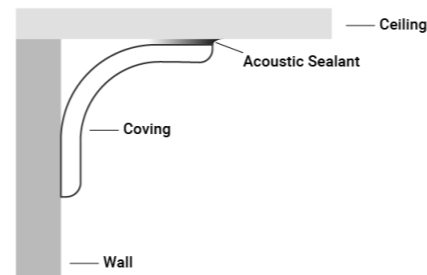

Finishing a carpet

- Adhere the skirting board to the wall.
- Leave a **2-5mm gap** from the floor so it is not in contact and fill with acoustic sealant.
- Remove the self adhesive film from the back of the carpet gripper isolation strip.
- Press onto the subfloor, **2-5mm** away from the skirting boards.
- Tack the carpet rod to the isolation strip.
- Fit your carpet up to the skirting board, cutting the excess.

Finishing a hard floor

- Adhere the skirting board to the wall.
- Leave a **2-5mm gap** from the floor and fill this with acoustic sealant.

Finishing vinyl flooring

- Roll the vinyl back and cut it **2-5mm** away from the wall.
- Adhere the skirting board to the wall.
- Leave a **2-5mm gap** from the floor and fill this with acoustic sealant.

Want to know more?

Call us: 01937 588 226
Email us: info@ikoustic.com
www.ikoustic.co.uk

Call our technical team Monday - Friday who will be happy to help.

You can also find a whole host of information on our website from systems to FAQs.